

DHI-ITC1652-AU5F-IRL8ZF1640

Dahua 16MP All-in-One Enforcement Camera



- GS-CMOS image sensor.
- 5320 × 3032@30 fps.
- Video compression standards: H.265, H.264M, H.264H and MJPEG.
- Works in poor lighting and does not smear.
- High-speed capture.
- Integrated design, IP66 and IK10 rated.

System Overview

With its high-performance AI processor, 16MP All-in-one IR. AI Enforcement Camera delivers excellent quality images even in the toughest weather conditions. For monitoring, it uses deep learning algorithms and traffic-specific, GS-CMOS image sensors with a wide dynamic range and high frame rate. The IR illuminators supplement light when the camera captures license plates without using the external flashing light or strobe, significantly reducing light pollution.

Functions

Reduced Light Pollution

The IR illuminators supplement light when the camera captures license plates without using the external flashing light or strobe, significantly reducing light pollution.

Ultra-high Frame Rate

Uses traffic-specific, high-performance GS-CMOS image sensors with a wide dynamic range, high frame rate, and high signal-to-noise ratio, displaying realistic video images in the day and night.

Video Metadata

Deep learning algorithms and a high-performance AI processor allow the camera to detect and extract detailed information on motor vehicles, providing a reliable data source that can be used in making effective decisions.

Applicable to Various Road Scenes

Ideal for scenarios where license plate recognition is needed, the camera is capable of capturing more than ten different types of traffic violations, and supports traffic information collection and event detection.

Multi-dimensional Data Sensing

Using GPS positioning, the camera realizes multi-dimensional data sensing.

Safe and Reliable Performance

Built to withstand the toughest conditions, this camera functions in a wide temperature and voltage range. It has a built-in lightning protection module. Feel safe using it in all-weather types.

Scene

The camera is ideal for use in intelligent traffic management and for smart city businesses. It is capable of detecting traffic violations, capturing license plates, generating passing vehicle records, collecting traffic data, and detecting events.

Technical Specification

Camera

Image Sensor	1.1" GS-CMOS
Shutter Mode	Single shutter; Double shutters; Three shutters
Electronic Shutter Speed	Auto/Manual 1/50 s–1/100,000 s
Noise Reduction	3D NR
S/N Ratio	48 dB
WDR	120 dB
Min. Illumination	0.001 lux
Day/Night	ICR auto switch: Uses IR cut-off filter (IRCF) with polarizer in the daytime, and uses ordinary filter at night.

Illuminator

Illuminator Number	8
IR Light	Yes
Illumination Distance	23 m–30 m (75.46 ft–98.43 ft) (brightness adjustable)
Lane Coverage	Center mount: 5 lanes Side mount: 4 lanes

Lens

Lens Type	Motorized Vari-focal
Focal Length	16 mm–40 mm
Max. Aperture	F1.4
Iris Type	P-Iris
Field of View	Horizontal: 21.4°–50.6° Vertical: 12.3°–28.9° Diagonal: 24.4°–58°

Function

Trigger Mode	Video trigger/Radar trigger
Speed Detection Range	0 km/h–300 km/h
OSD Overlay	Time; address; lane No.; plate; plate color; and more
Alarm Event	Storage full; storage error; external alarm; no storage card; license plate blacklist; illegal access; network disconnection; IP conflict
Automatic Network Replenishment (ANR)	Platform and FTP (TF card is required)
Auto Registration	Yes

Intelligence

Target Detection	Motor vehicle; motorcycle
Face Detection	Detects the driver and front-seat passenger of motor vehicles, and motorcycle drivers; extracts face images
ANPR	Adopts developed algorithms to recognize license plate numbers and letters
Vehicle Type Recognition	Vehicle head: SUV, Large bus, sedan, light truck, pickup, heavy truck, medium truck, van, medium bus, MPV Vehicle tail: SUV, large bus, sedan, light truck, pickup, heavy truck, medium truck, van

Vehicle Color Recognition	White, pink, black, red, yellow, gray, blue, green, dark orange, purple, brown, and silver gray (color recognition is not supported during the nighttime)
Vehicle Brand/Logo Recognition	Vehicle head mode: Acura, Alfaromeo, Ashokleyland, Astonmartin, Audi, Baic, Bently, Benz, BMW, Buick, BYD, Cadillac, Chery, Chevrolet, Chrysler, Citroen, Dacia, Daihatsu, Datsun, Dodge, DS, Ferrari, Fiat, Force, Ford, Foton, Geely, GMC, Greatwall, Hino, Honda, Hyundai, Infiniti, Isuzu, Iveco, Jac, Jaguar, Jeep, Kia, Kinglong, Land, Lexus, Lifan, Lincoln, Mahindra, MAN, Maserati, Mazda, Mercury, MG, Mini, Mitsubishi, Nissan, Opel, Peugeot, Porsche, Renault, Rollsroyce, Saab, Scania, Seat, Skoda, Smart, Subaru, Suzuki, Tata, Tesla, Toyota, UD, Volkswagen, Volvo
Motor Vehicle Violation Capture	ANPR mode: Wrong-way driving, speeding, driving slow, crossing the solid white line, crossing the solid yellow line, illegal lane change, unfasten seat belt, calling while driving, smoking while driving E-Police mode: Running a red light, wrong-way driving, crossing the solid white line, crossing the solid yellow line, disobeying the direction arrow, illegal left turn, illegal right turn, illegal U-turn (not supported by side-mounted cameras), and crossing the stop line
Motorcycle Violation Capture	Captures traffic violations including carrying passenger, not wearing helmet, and wrong-way driving
Traffic Flow Detection	Generates statistics on vehicle flow, queue length, average speed, lane occupancy, and more
Traffic Event	Motor vehicle illegal stopping on the roadway; traffic congestion

Video

Video Compression	H.265; H.264M; H.264H; MJPEG
Video Resolution	5320 (H) × 3032 (V)
Video Frame Rate	50Hz: Maximum 25 fps; default main stream (4096 × 2160@12.5fps), sub stream (1600 × 1200@12.5 fps) 30Hz: Maximum 30 fps; default main stream (4096 × 2160@15 fps), sub stream (1600 × 1200@15 fps)
Video Bit Rate	H.264: 32 kbps–32767 kbps H.265: 32 kbps–32767 kbps MJPEG: 512 kbps–32767 kbps
Bit Rate Control	CBR/VBR
White Balance	Auto; Night; Customized Color Temperature
Edge Enhancement	Yes
HLC	Yes
BLC	Yes
Bad Pixel Correction	Yes
Gain Range	0–100

Image

Composite Image	Supports combining up to 4 images into a composite image
Image Resolution	5320 (H) × 3032 (V) (OSD black strip excluded)
Image Encoding Format	JPEG
Image Tampering Prevention	Verifies watermarks in videos and images

Network

Network Port	2 × RJ-45 Ethernet ports, 10/100/1000 M network transmission
--------------	--

All-in-One Enforcement Camera | DHI-ITC1652-AU5F-IRL8ZF1640

SDK and API	Yes
Security	Authorized username and password, MAC address binding, HTTPS encryption, and network access control
Network Protocol	IPv4/IPv6; HTTP; TCP/IP; UDP; NTP; DHCP
Interoperability	ONVIF (Profile S/Profile G/Profile T)
Browser	Microsoft Edge IE: IE9-IE11 Chrome: Chrome 41 and earlier Firefox: Firefox 49 and earlier For Win 10 users, run the browser as administrator
Positioning	GPS
Network Status Monitoring	NTP; GPS

Port

Storage	1, TF card (maximum 256 GB@Class10)
Iris Control	1, connects to DC auto iris or P-IRIS
Focus Control	1, connects to motorized vari-focal lens
Frequency Source Sync	1, supports synchronizing the camera with the mains electricity
Peripheral Light	7, optocoupler signal output (can be configured as flash light or LED strobe sync output interface, frequency adjustable)
USB	2 USB 3.0 Ports
RS-485	2, connects to devices such as signal detector, radar, and more
RS-232	4 (3 for radar connection, and 1 for serial port debugging)
I/O	4, same functions as ALARM IN port
Audio Input	1 channel (3.5mm JACK port)
Audio Output	1 channel (3.5mm JACK port)
Alarm Input	4, same functions as I/O port
Alarm Output	2 (AO1 is for relay output and AO2 for optocoupler output)
Power Output	12 VDC ± 10% voltage output, ≤1.5 A current output

General

Power Supply	100-240 VAC (50 Hz/60 Hz)
Power Consumption	≤20 W
Operating Temperature	-40 °C to +65 °C (-40 °F to +149 °F)
Storage Temperature	-40 °C to +70 °C (-40 °F to +158 °F)
Operating Humidity	10%-90% (RH)
Storage Humidity	0%-90% (RH)
Certifications	CE LVD: EN62368-1; IEC 60950-22; IEC62471 CE EMC: EN55032; EN55035; IEC61000-3-2; IEC61000-3-3
Protection	IP66, IK10
Product Dimensions	554.0 mm × 204.2 mm × 209.6 mm (21.81" × 8.04" × 8.25") (L × W × H)

Net Weight	4.6 kg (10.14 lb)
Gross Weight	6.6 kg (14.55 lb)
Installation	Center mount; side mount

Ordering Information

Type	Model	Description
AI Enforcement Camera	DHI-ITC1652-AU5F-IRL8ZF1640	16MP all-in-one AI enforcement camera
Accessories (Optional)	8019	3-dimensional universal mounting bracket (purchase separately)
	3012	Side mounting bracket (purchase separately)
	PFA150	Mounting bracket (purchase separately)

Accessories

Optional:



8019
3-dimensional universal mounting bracket (purchase separately)



3012
Side mounting bracket (purchase separately)



PFA150
Mounting bracket (purchase separately)

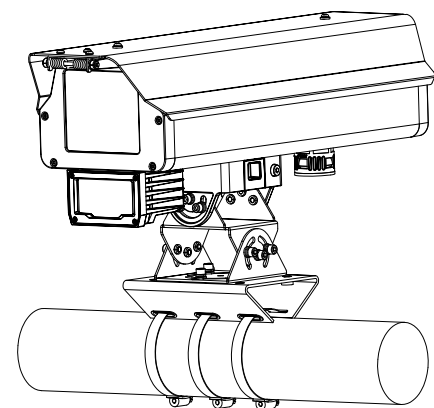
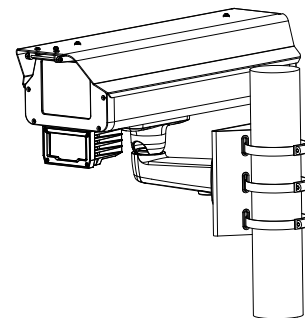

Dimensions (mm [inch])

